

PATIENT INSTRUCTIONS

Dynasplint® Supination/Pronation Forearm System

Corporate Headquarters:
800.638.6771 toll-free
800.380.3784 fax

Canada:
800.668.9139 toll-free
905.851.3494 fax

Europe:
00131.455 230 418 phone
00131.455 231 303 fax

www.dynasplint.com

I acknowledge receipt of these patient instructions, which I have read and fully understand.

Signature

Print Name

Date

IMPORTANT: Read instructions thoroughly before wearing the Dynasplint® Supination/Pronation Forearm System. Be sure that the splint fits comfortably and properly. If you feel pain, numbness, swelling, or skin irritation remove the splint immediately and contact your Dynasplint® Systems sales consultant. If joint stiffness persists longer than one hour after wearing the unit, reduce the tension by 0.5 increments, approximately $\frac{1}{2}$ turn. Contact your Dynasplint® Systems sales consultant if you have any questions.

DYNASPLINT® and Dynasplint® Systems are registered trademarks of Dynasplint Systems, Inc.
Rev. 06/2017



Stretch Beyond Your Expectations.®

FITTING INSTRUCTIONS

APPLYING THE DYNASPLINT® SUPINATION/PRONATION FOREARM SYSTEM:

STEP 1: Open completely or loosen upper arm cuff and wrist stabilizer strap.

For Supination:

STEP 2: With the mobile pin (See Figure 2) removed and the Dynasplint® System reading “Supination” when looking from the wrist stabilizer to the mechanical joint centered just outside the distal-most ring, slip your arm into the system so that the thumb is seated all the way through in the wrist stabilizer. Secure with the hook and loop fasteners around the wrist and upper arm. See Figures 1 & 2.

FIGURE 1.

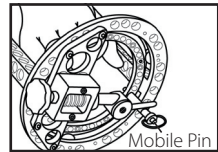
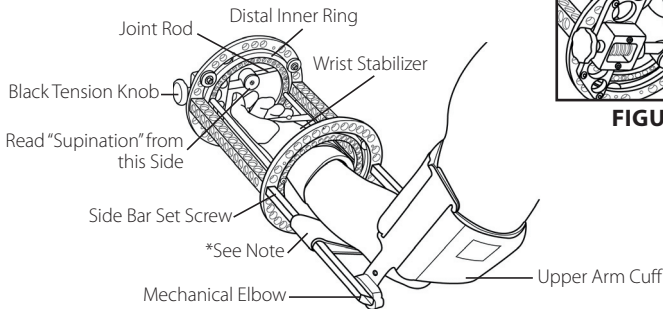

FIGURE 2.

For Pronation:

STEP 2: With the mobile pin removed and the Dynasplint® System reading “Pronation” when looking from the wrist stabilizer to the mechanical joint centered just outside the distal-most ring, slip your arm into the system so that the thumb is seated all the way through in the wrist stabilizer. Secure with the hook and loop fasteners around the wrist and upper arm. See Figure 2.

STEP 3: Align the side bar with midlines of the sides of the lower arm and the mechanical elbow with your elbow.

FIGURE 2.

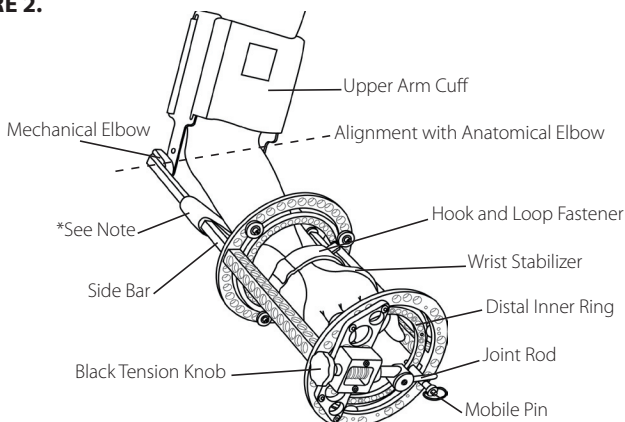

STEP 4: Check both the cuff and straps for tightness.

STEP 5: While the Dynasplint® System is in place, the arm should not hang down. You should be inactive and relaxed. The most comfortable position while sitting and sleeping is with the arm supported on a pillow.

REMOVING THE DYNASPLINT® SUPINATION/PRONATION FOREARM SYSTEM:

STEP 1: Decrease tension

STEP 2: Open completely or loosen upper arm cuff and on wrist stabilizer.

STEP 3: Remove hand and arm from splint.

Continue to follow your physician's or therapist's instructions regarding your home therapy program while wearing the Dynasplint® System. Record your comments daily on the evaluation sheet (back page of booklet) for review with your Dynasplint® Systems sales consultant.

CLINICIAN'S PRESCRIBED TREATMENT SCHEDULE

These are guidelines only. Remove the Dynasplint® System if you experience pain at any time and contact your Dynasplint® Systems sales consultant.

Tension to be initially set at _____ increments.

Patient will wear the Dynasplint® System for _____ minutes/hours the first day.

If no more than one hour post-wear discomfort occurs, the patient may increase wear time according to the recommended daily wearing schedule, building up to 2-3 sessions per day, 1-2 hours per session. Time spent wearing the splint is the most important component in regaining range of motion.

Increase tension by 0.5 – 1 increment on both sides of the splint if less than one hour of post-wear discomfort occurs after use.

Decrease tension if unable to wear for extended period of time.

Maximum tension: _____.

The basic protocol outline is to provide maximum benefit from the Dynasplint® System. *Increasing tension faster does not ensure proper stretch will be applied.*

Remember to wear the Dynasplint® System while inactive.

Your follow-up visit is _____ .

Please bring the Dynasplint® System and the completed evaluation sheet.

Sales Consultant: _____ Voicemail Number: _____

DYNASPLINT® SYSTEMS PATIENT EVALUATION SHEET

Date	Hours of Wear	Tension Setting	Daily Goal	Duration of Post-Wear Stiffness	Comments

Continue to report your progress on a separate sheet of paper.

4 POINT SUMMARY

1. NO PAIN while wearing the Dynasplint® System.
2. Time is the most important component.
3. Increase tension after 6-8 hours of wear if at most one hour post-wear discomfort occurs.
4. Decrease tension if unable to wear.

©1996 Dynasplint Systems, Inc.

Dynasplint Systems, Inc. products are covered by one or more of the following U.S.A. patents: 5,558,624; 5,645,521; 6,413,231; 6,506,172; 6,740,051; 6,908,475; 6,942,629; 6,942,631; 4,485,808; 4,508,111; 4,538,600; 4,944,290; 4,947,835; and 5,070,868. Other patents issued and/or pending in the U.S.A. and internationally.

The product described in the enclosed literature is intended for the specific purpose as per the instructions attached. Any use of this product outside of its intended purpose on any body part or in a manner outside the protocol established by Dynasplint Systems, Inc., is a use of the product for which it, its divisions and employees cannot be held responsible. All implied warranties of fitness for use for any other purpose (or purposes) are expressly disclaimed.